

EC-E-SL

TECHNICAL DATA

CW

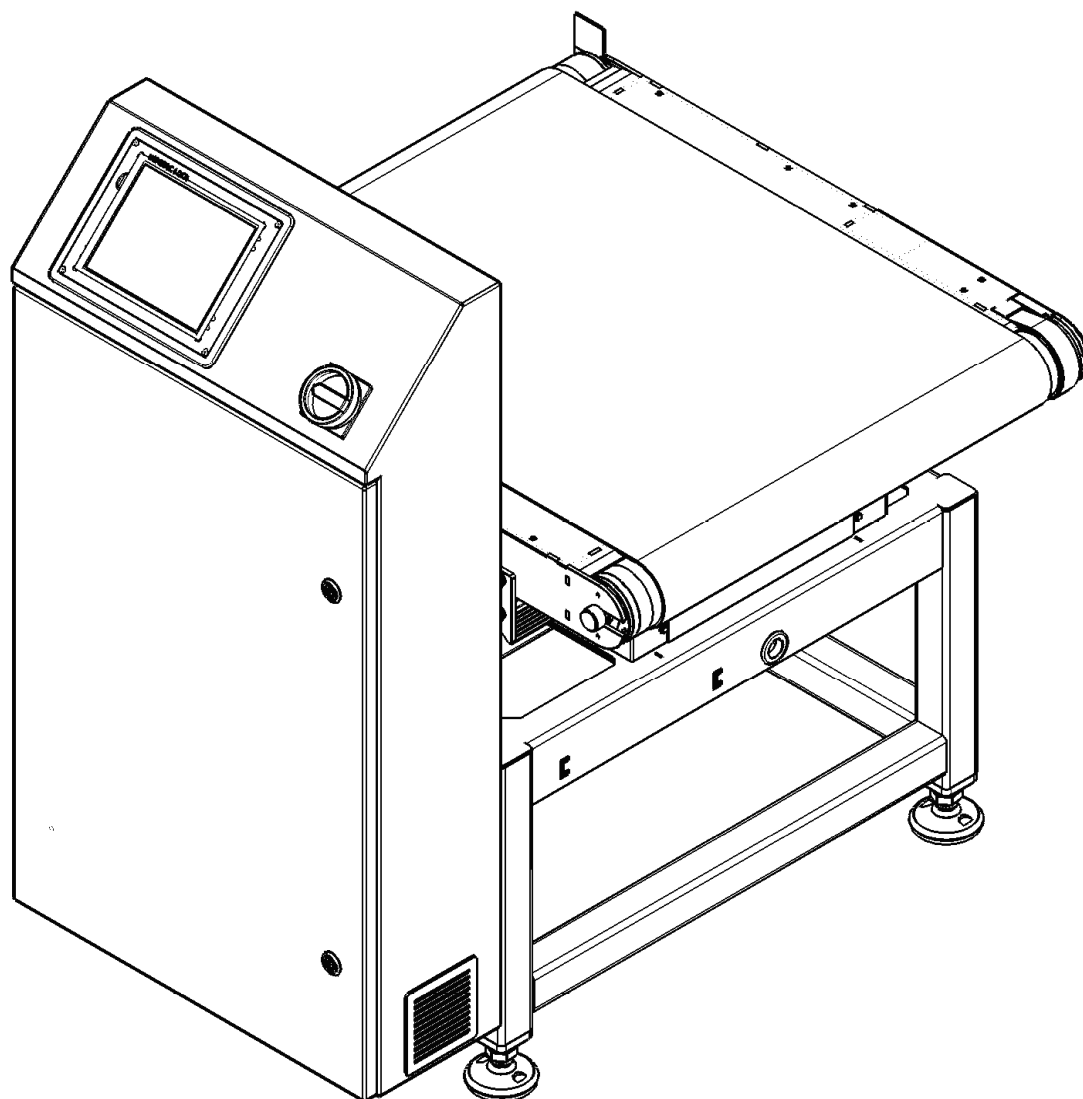

COMPLETE AND COMPREHENSIVE – ESSENTIAL FOR THE HEAVY LOADS

EC-E SL

A practical addition to the ESSENTIAL series, the **EC-E-SL** is designed for high precision weighing of larger or heavier product formats.

Whether checking individual products midway through the production process or making the final control check of the repackaged units at the end of the line before palletization, the EC-E-SL is the perfect system for both needs.

A well-designed 8-inch, color touch-screen provides the operator interface to ensure easy control. Your advantage: all checkweighers and X-ray scanners installed in your lines use only one standard,

interactive and intuitive, operating philosophy. The operator no longer has the inconvenient and time consuming task of switching between programs.

Thanks to a variety of readily available options, the main weighing unit of the EC-E-SL can be complemented with appropriate input and output conveyors, for example, with a diverse choice of separation/ejection options that include pulse output and belt stop.



MAIN FEATURES

- ✔ **Modular and flexible weighing technology for larger or heavier products**
- ✔ **User friendly interface via 8" colour TFT touchscreen display**

YOUR BENEFITS

- ✔ **Max. output 100 ppm**
- ✔ **WIPOTEC EMFR Weigh Cell for optimal weighing results**

TECHNICAL DATA

EC-E SL

BASE DATA

Material of machine	Steel, RAL 7035 powder-coated
Machine weight (standard application)	160 kg
Shipping weight (standard application)	200 kg
Protection class	IP54 ¹⁾
Temperature range	+5 °C to +40 °C
Display and operation	8" colour TFT display with touchscreen
Available dialog languages	Bosnian, Chinese, Croatian, Czech, Danish, Dutch, English, Finnish, French, German, Greek, Hungarian, Italian, Japanese, Latvian, Lithuanian, Polish, Portuguese, Russian, Slovak, Slovenian, Spanish, Swedish, Turkish (other languages on request)
Interfaces ²⁾	Optionally: Ethernet, RS232, RS422, RS485
Max. output ³⁾	100 pcs/min
Digital I/O	8xI + 12xO
Product parameter storage	50 PPS (optionally 100 / 200 PPS)
Drive	Servo-Technology
Noise level ³⁾	A-weighted emission sound pressure level under 70dB(A)
Rated voltage	L1/N/PE; 100-240 VAC
Rated frequency	50/60 Hz
Connect load (power capacity)	Approx. 1.4 kVA
Compressed air supply (option)	8 bar approx. 10NI/min quality class (according to ISO 8573-1) [5:3:3]
Possible maximum numbers of connected motors	1 motor (optionally 1 extendible)
EU-type examination certificate	DE-18-MI006-PTB001 (MID)

WEIGHING DETAILS

	Weigh Cell (Typ)	GWR (Gross weighing range)	Dead load max.	e (min. calibration value)	d (Displayed value)	Standard deviation ³⁾ (1s)	n (Scale division)
EC-E-SL	IW-B-60K	35,000 g	30,000 g	≥ 20 g	≥ 2.0 g	from 2 g	1,750

1) Water from above, for IP65 full protection, see VA-application or WD-application (IP69K)

2) Optionally, surcharge

3) Depending on product shape, product behavior, transport speed and environmental condition

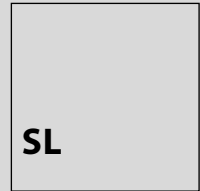

CONVEYOR DIMENSIONS

		Dimensions weighing conveyor	
length \ width		500 mm	600 mm
600 mm		x	-
800 mm		x	x
1,000 mm		-	x

		Dimensions infeed / outfeed conveyor	
length \ width		500 mm	600 mm
600 mm ¹⁾		x	-
800 mm ¹⁾		x	x
1,000 mm ¹⁾		-	x

1) Optionally, surcharge

MACHINE DIMENSIONS

EC-E SL

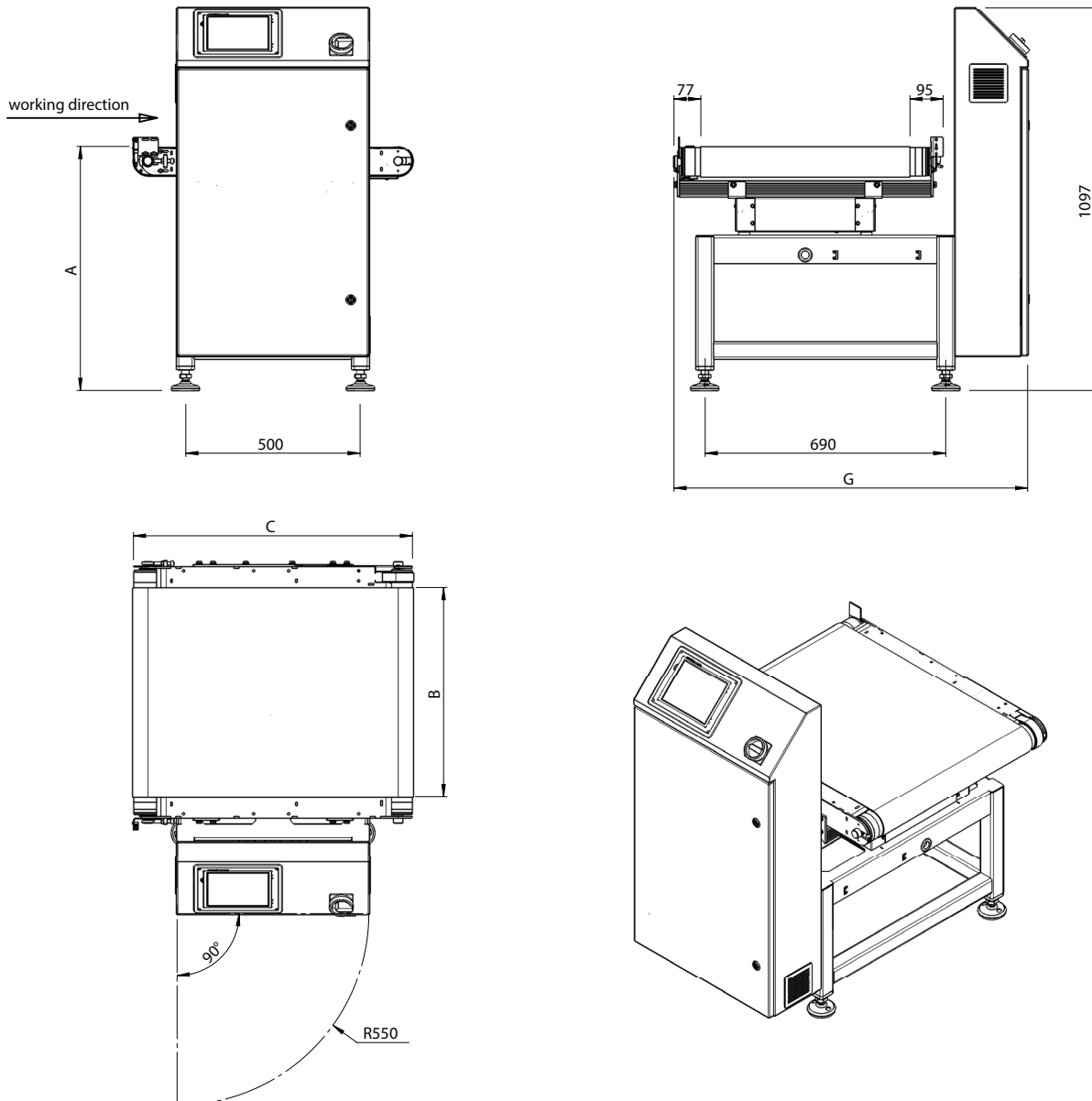

A = Working height¹⁾	560-650 ²⁾ / 600-750 / 700-850 / 800-950 / 900-1,050 ²⁾ mm
B = Conveyor width	500 / 600 mm
Conveyor technology EVO	roller diameter 80 mm
C = Weighing conveyor length	600 / 800 / 1,000 mm
D= Infeed conveyor length	600 ²⁾ / 800 ²⁾ / 1,000 ²⁾ mm
E = Outfeed conveyor length	600 ²⁾ / 800 ²⁾ / 1,000 ²⁾ mm
F = Total length	C + 5 mm
G = Total width	1,015 mm depending on machine configuration

1) Working height must be specified when ordering

2) Optionally, surcharge

These specifications are reference values of the standard machine excluding application- or weighing-specific add-on parts.
All entries in mm | Drawing shows design example

