

HC-M-SL

TECHNICAL DATA

CW

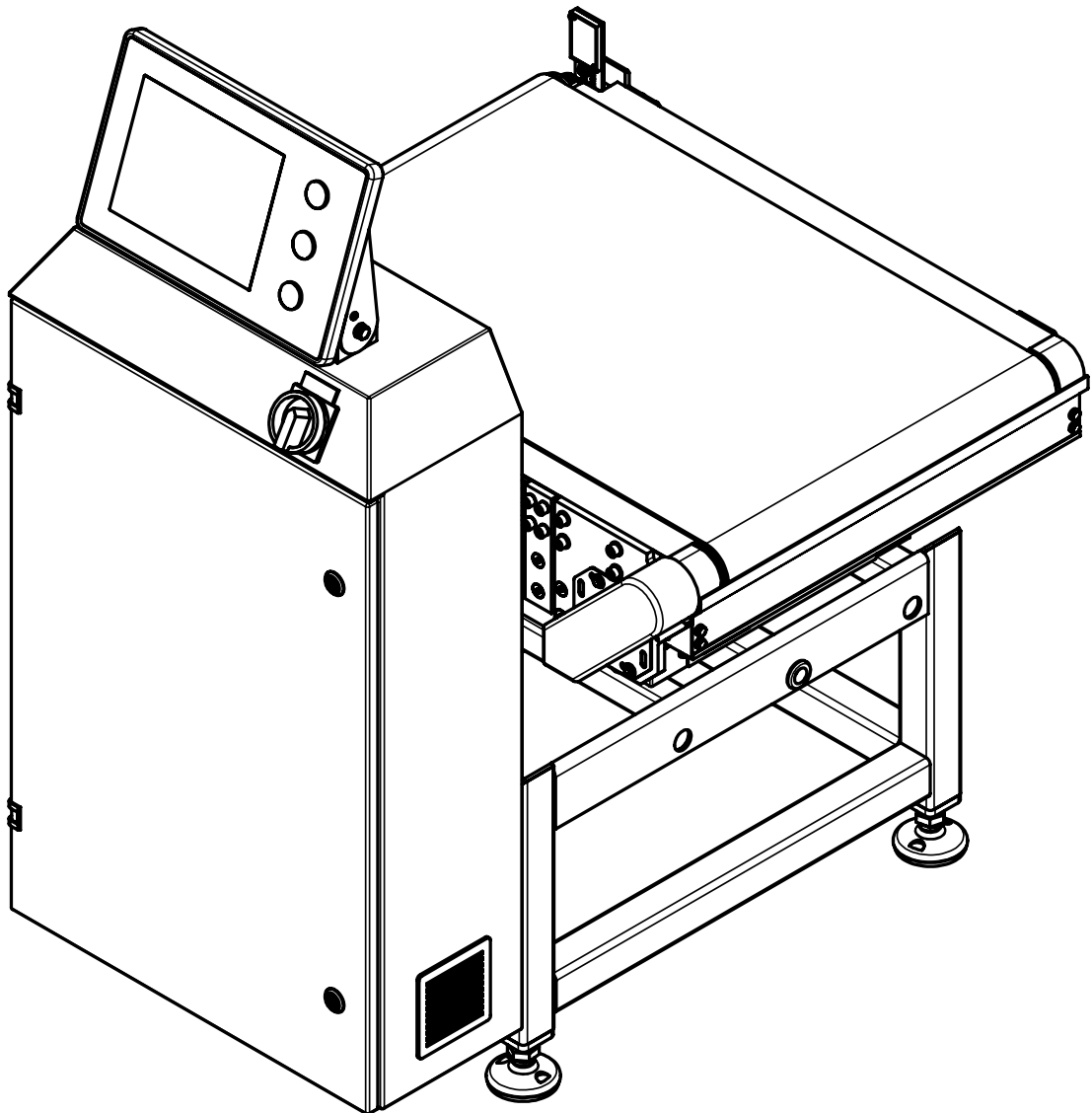

HEAVY LOAD CHECKWEIGHER FOR PRECISE WEIGHT DETERMINATION

HC-M SL

For products individually weighing up to 60 kg, the WIPOTEC-OCS heavy load checkweigher **HC-M-SL** offers optimum conditions for highly dynamic checking of current product weights or carrying out completeness checks. With belt speeds up to 2 meters per second, it can be integrated into high-speed production lines.

The lightweight, patented conveyor systems and the particularly carefully balanced drive concept ensure maximum smoothness with smooth running and fast, safe product transport. The HC-M-SL is available in a wide range of conveyor length and conveyor width combinations, enabling

individually tailored solutions for a wide range of product shapes.

A wide and sophisticated range of optional rejection and sorting devices (e.g. pushers, flap conveyor, etc.) are available for the heavy load checkweighers to reliably

reject products with incorrect weight. All models are supplied as a complete system with base frame and control cabinet in stainless steel and meet the specifications according to protection class IP54.



KEY FEATURES

- ✔ Maintenance-free asynchronous motors
- ✔ Type approval (MID)
- ✔ WIPOTEC EMFR Weigh Cell
- ✔ Easy, menu-driven operation via 10.4" colour TFT display with touchscreen
- ✔ Easy belt and conveyor replacement
- ✔ Flexible integration into production lines
- ✔ Line synchronisation with dry-contact I/O signals

YOUR BENEFITS

- ✔ Complete system for precise weight determination/completeness check
- ✔ Belt speeds up to 2 m/s
- ✔ Easy, user-friendly operation
- ✔ Low-noise conveyor system

TECHNICAL DATA

HC-M SL

BASE DATA

Material of machine	Frame in solid stainless steel design	
Machine weight (standard application)	150 kg	
Shipping weight (standard application)	250 kg	
Protection class	IP54	
Temperature range	+5 °C to +40 °C	
Display and operation	Cabinet with tiltable 10.4" colour TFT touch screen (optionally free-standing cabinet)	
Available dialog languages	Bosnian, Chinese, Croatian, Czech, Danish, Dutch, English, Finnish, French, German, Greek, Hungarian, Italian, Japanese, Latvian, Lituania, Polish, Portuguese, Russian, Slovak, Slovenian, Spanish, Swedish, Turkish (other languages on request)	
Interfaces ¹⁾	Optionally: RS232, RS422, RS485, Ethernet, USB (for printer and backup)	
Rate of speed	HC-M-SL-1: max. 1.0 m/s (optional to 2.0 m/s)	HC-M-SL-2: max. 2.0 m/s
Digital I/O	8xE + 8xA (optionally extendible)	
Product parameter storage	100 PPS (optionally 200 / 400 PPS)	
Drive	Asynchronous motor with frequency inverter	
Noise level ²⁾	A-weighted emission sound pressure level under 70dB(A)	
Rated voltage	L1/N/PE, alternatively 115 VAC or 230 VAC	
Rated frequency	50/60 Hz	
Connect load (power capacity)	Approx. 1.8 kVA	
Compressed air supply (Option)	6 bar approx. 16NI/min quality class (according to ISO 8573-1) [5:3:3]	
Possible maximum numbers of connected motors	1 motor (optionally 2 extendible)	
EU-type examination certificate	DE-18-MI006-PTB001 (MID)	

WEIGHING DETAILS

	Weigh Cell (type)	GWR (Gross weight range)	Dead load max.	e (Min. calibration value)	d (Displayed value)	Standard deviation ²⁾ (1s)	n (Scale division)
HC-M-SL-1	IW-B-60k	30,000 g	60,000 g	≥ 5.0 g	≥ 0.5 g	from 500 mg	6,000
HC-M-SL-2	IW-B-150k	60,000 g	150,000 g	≥ 10.0 g	≥ 1.0 g	from 500 mg	6,000

1) Optionally, surcharge

2) Depending on product shape, product behavior, transport speed and environmental condition

TECHNICAL DATA

HC-M SL

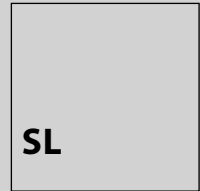

CONVEYOR DIMENSIONS

		HC-M-SL-1 conveyor type SL60			HC-M-SL-2 conveyor type SL80S	
length \ width		400 mm	500 mm	600 mm	600 mm	800 mm
600 mm		X	X	-	-	-
700 mm		X	X	X	-	-
800 mm		X	X	X	-	-
900 mm		X	X	X	-	-
1,000 mm		X	X	X	X	X
1,100 mm		-	-	-	X	X
1,200 mm		-	-	-	X	X
1,300 mm		-	-	-	X	X

MACHINE DIMENSIONS

HC-M-SL-1

HC-M SL

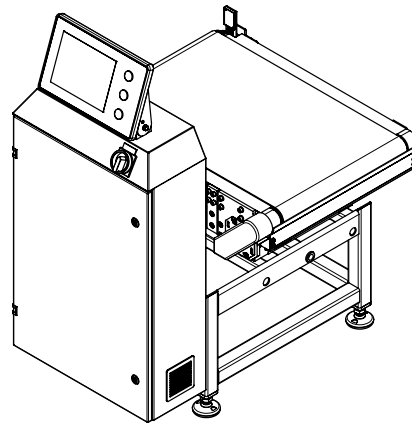
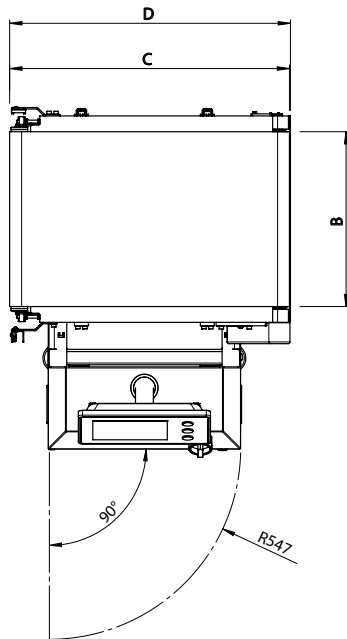
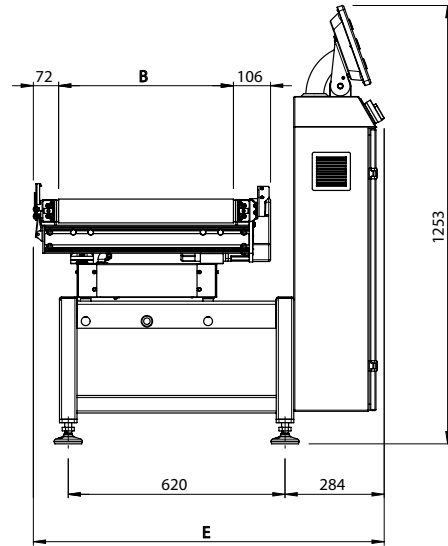
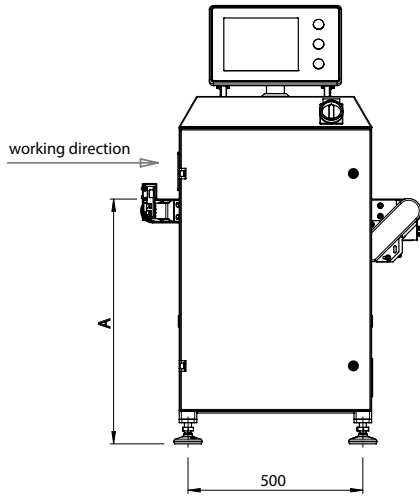

A = Working height¹⁾	600-750 / 700-850 / 800-950 mm (optionally 550-650 / 900-1,050 mm)
B = Conveyor width	400/500/600 mm
conveyor type SL60	roller diameter 60 mm
C = Weighing conveyor length	600 / 700 / 800 / 900 / 1,000 mm
D = Total length	C + 5 mm
E = Total depth	955 mm to B = 400 mm 1,005 mm to B = 500 mm 1,055 mm to B = 600 mm

1) Specify working height when ordering.

These specifications are reference values of the standard machine excluding application- or weighing-specific add-on parts.
All entries in mm | Drawing shows design example

MACHINE DIMENSIONS

HC-M-SL-2

HC-M SL

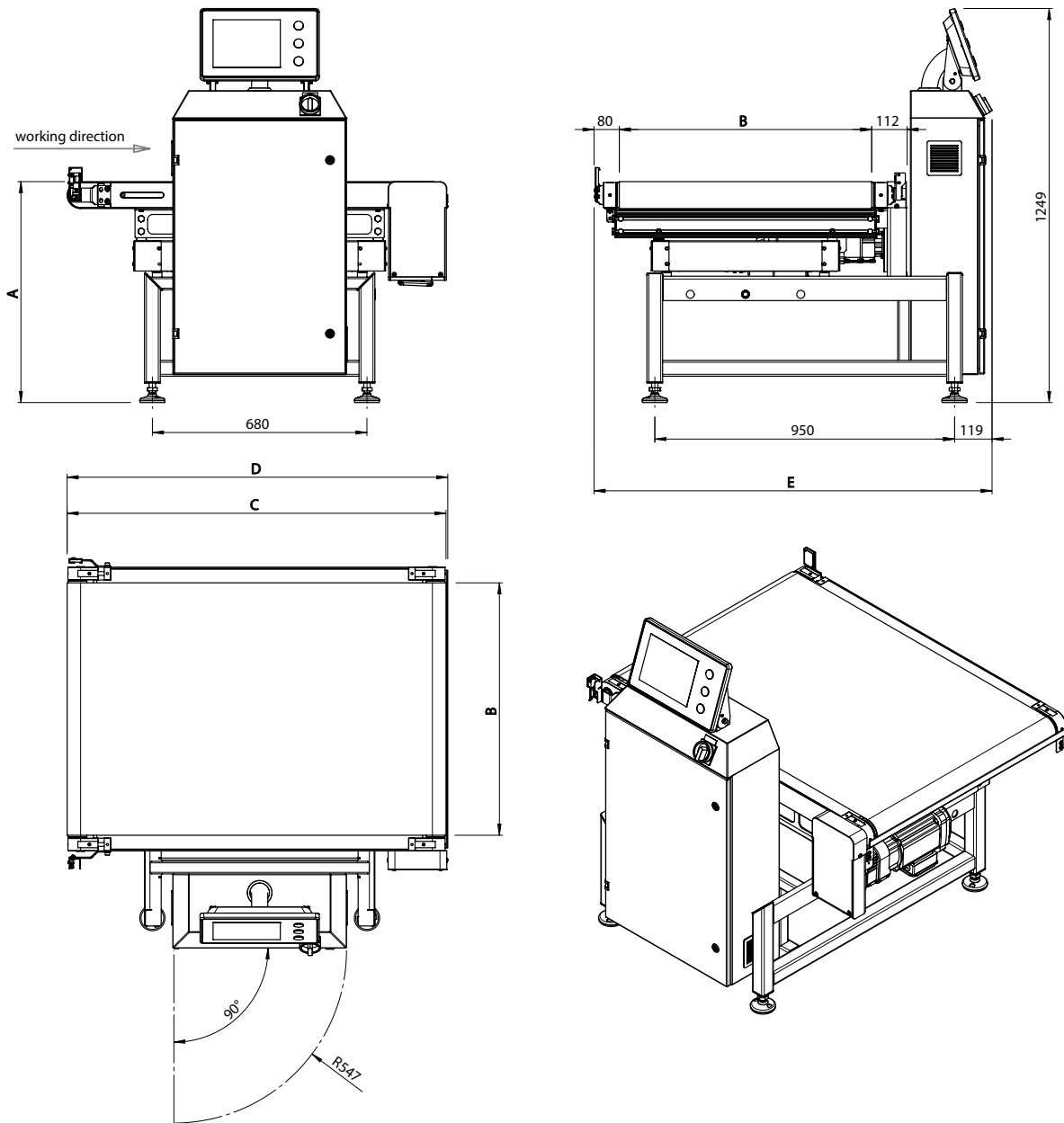

A = Working height¹⁾	600-750 / 700-850 / 800-950 mm (optionally 550-650 / 900-1,050 mm)
B = Conveyor width	600 / 800 mm
conveyor type SL80S	roller diameter 80 mm
C = Weighing conveyor length	1,000 / 1,100 / 1,200 / 1,300 mm
D = Total length	C + 5 mm
E = Total depth	1,161 mm to B = 600 mm 1,261 mm to B = 800 mm

1) Specify working height when ordering.

These specifications are reference values of the standard machine excluding application- or weighing-specific add-on parts.
All entries in mm | Drawing shows design example

